

**GEM STATE  
RODEO ASSOCIATION  
RULE BOOK**

**BY-LAWS AND RULES**  
IN ADDITION TO  
NATIONAL HIGH SCHOOL RODEO  
ASSOCIATION  
RULE BOOK

Rev. 2023

## **ARTICLES**

KNOW ALL MEN BY THESE PRESENTS, That we, the undersigned, all of whom are citizens of the United States, of legal age, have this day voluntarily associated ourselves together for the purpose of forming a nonprofit cooperative association under and by virtue of the laws of the State of Idaho relating to nonprofit cooperative associations, and more especially Title 30, Chapter 3, et sequitur Idaho Code, and we hereby certify:

### **ARTICLE 1 NAME**

The name of this corporation shall be: GEM STATE RODEO ASSOCIATION, INC., hereinafter referred to as G.S.R.A.

### **ARTICLE 2 PURPOSE**

The purposes for which this corporation is formed are:

1. To organize qualified amateur sports competition in the State of Idaho that promotes rodeo for the purpose of promoting their mutual protection and benefit. This organization will be organized for the sole purpose of promoting amateur sports and not inure to the benefit of private shareholders or individuals.
  - A. To require that all entrance fees are added to prize money with exceptions being at the discretion of the contestants.
  - B. To secure competent, honest judges and officials in all events.
2. To protect the members against unfairness on the rodeo management.
3. To publish information concerning the dates of rodeos, names of contestants, the prize money and other pertinent particulars concerning contestants, promoters and sponsors in which the public and members of the G.S.R.A. are interested.
4. To work for the betterment of conditions and rules governing rodeo events in which members of the Association participate.
5. To provide a uniform set of rules for the contestants of the G.S.R.A., and for the guidance and direction of judges of all G.S.R.A. rodeos.
6. To elect or appoint officers and agents of the corporation who may be directors or members, and define their duties and fix their compensation.

### **ARTICLE 3 EXISTENCE**

This corporation shall be in perpetual existence.

### **ARTICLE 4 CORPORATE OFFICE**

The address of the initial registered office and the name of the initial registered agent of such office shall be Marilyn Taylor Rt. 1, Eagle, ID

### **ARTICLE 5 INCOME AND ASSETS**

No part of the income or assets of the corporation shall be distributed to, or inure to the benefit of any individual.

**ARTICLE 6  
BOARD OF DIRECTORS**

The affairs and activities of this corporation shall be managed by the officers and the Board of Directors of said corporation.

**ARTICLE 7  
LIABILITIES**

No member, officer, director, employee, agent or attorney shall be personally responsible or liable for any debts, costs or judgments imposed upon or against or incurred by the corporation unless such person shall be adjudged to be liable for negligence or misconduct in the performance of this duty to the corporation.

**ARTICLE 8  
ENUMERATED POWERS**

The purposes and powers enumerated herein are to be construed both as purposes and powers and shall be in no way limited or restricted by reference to or inference from any other items of this certificate. Each of the purposes and powers specified shall be regarded as independent purposes and powers and are not intended to be in limitation of the general powers granted to corporations under the laws of the State of Idaho, but are intended to be, and shall be held to be, in furtherance thereof.

**ARTICLE 9  
RULES OF ORDER**

Robert's Rules of Order, revised shall govern this Association in all cases, in which they are applicable and in which they are not inconsistent with these articles.

**ARTICLE 10  
AMENDMENTS**

These articles may be amended at any regular meeting of this Association by a 2/3's majority vote of the quorum present, provided notice of the proposed amendment shall have been given at the previous regular meeting and posted in the newsletter preceding such meeting. For the purpose of G.S.R.A. the quorum will consist of 12 members.

**ARTICLE 11  
DISSOLUTION**

Upon dissolution of this organization, the assets shall be distributed for one or more exempt purposes within the meaning of section 501(c)(3) of the Internal Revenue Code, or corresponding section of any future federal tax code, or shall be distributed to the federal government, or to a state or local government, for a public purpose.

**GENERAL RULES**

**ARTICLE 1  
OFFICERS AND BOARD OF DIRECTORS**

**SECTION 1: DUTIES OF THE OFFICERS**

The Board of Directors shall consist of eleven (11) members as follows:

President	Vice President
Secretary	Treasurer
Fundraising Committee Chairperson	Six (6) Adult Directors (elected)

1. The President shall preside at all meetings of the Association. The President shall be the chairman of the Board of Directors and a member ex-officio of all committees except the nominating committee. The President shall not be entitled to vote except in the event of a tie. In the absence of the President, the Vice-President shall assume the duties of the President. In the event of a vacancy occurring in the office of President, the Vice-President shall serve as

president until the next annual election of officers.

2. The Secretary shall keep minutes of all meetings of the Association, and shall preserve all documents of the Association, publish a monthly newsletter, accept fees and applications for new contestants and nonmembers and keep an up-to-date mailing list of paid names and addresses.
3. The Treasurer shall work with the Secretary and collect, receive and deposit all funds in the bank. The Treasurer and Secretary shall have charge of all funds of the Association. The Treasurer shall work with the Secretary in providing for pay-offs at each rodeo. The Treasurer shall be bonded if the Association requires it, the fee to be paid by the Association.
4. All officers and directors shall serve without salary.
5. All officers and directors may be removed at any time with or without cause by a majority vote of those who have paid to vote, after notice has been given of such action.
6. Resignation of officers and directors must be presented in writing to the President. \_

#### SECTION 2: QUALIFICATIONS AND TERMS

1. The President and Vice-President will be fulfilled as follows: Year #1 the President will be elected for a 2-year term. Year #2 the Vice President will be elected for a 2-year term. Year #3 the President will again be elected... etc. The elections will be by popular vote to serve calendar years from January 1st to December 31st.
2. The Secretary and the Treasurer will be fulfilled as follows: Year #1 the Secretary will be elected for a 2-year term. Year #2 the Treasurer will be elected for a 2-year term. Year #3 the Secretary will again be elected . . . etc. The elections will be by popular vote to serve calendar years from January 1<sup>st</sup> to December 31<sup>st</sup>.
3. The following appointments shall be elected by popular vote to serve a term of one year: Event Directors, Arena Director, Fundraiser Chairperson, Awards Chairman, and Banquet Chairperson.

#### SECTION 3: NOMINATIONS AND ELECTIONS

1. The President shall appoint a nominating committee no later than the Rodeo Finals. Said committee members shall nominate needed candidates for offices of President, Vice-President, Secretary, Treasurer, and Board of Directors. Nominations shall not be limited to these candidates, but can also be made from Association body during the elections.
2. Election of officers will be held prior to December 31.
3. Only persons in good standing shall vote for nominations or elections of officers.

#### SECTION 4: POWERS OF ASSOCIATION

1. The legislative or rule making powers of the Association shall be held by the general body of the Association. The Association shall have supervision over the business and affairs of the Association with the power to make, alter, or amend the by-laws as herein specified.

2. The Officers and Board of Directors as a body shall not be authorized to make any decision effecting the Association's rules or monies without the majority vote of the Association, except in situations where a decision must be made immediately and is in the best interest of the Association, and a general Association meeting would be impractical to hold. All such decisions must be reported to the General Membership and the Association shall, by electing responsible people to hold offices and seats on the Board of Directors, stand behind such decision, but shall not be limited or restricted to such decisions on future or similar cases.
3. An annual meeting of the newly elected officers and board of directors will meet to set the rodeo dates for the upcoming year.

#### SECTION 5: MEETINGS

1. An annual meeting of the General Membership shall be held at the beginning of each calendar year (December 31 through December 30) the place of the meeting and date set by the newly elected Officers to inform the membership of the rodeo dates for the upcoming year.
2. The President may call a meeting at any time provided each paid contestant or voting member is given advanced notice of the meeting.

### **ARTICLE II REGULATIONS FOR CONTESTANTS**

#### SECTION 1. CONTESTANT FEES

1. Eligibility of contestants and non-contestants: Contestants will be designated as follows, with age requirements as of January 1, applying for the full year:
 

Mini Mites	7 and under
Pee Wees	8 through 10
Juniors	11 through 13
Seniors	14 through the eligible age of High School Rodeo Rules & last year of High School eligibility.
2. Annual fees for vote (includes newsletter and rulebook) or contestant (eligibility to compete, vote, newsletter and rulebook). Voting members must be paid members or an elected official.

#### MEMBERSHIP FEES:

- |            |                                  |
|------------|----------------------------------|
| A. Members | \$50.00 If paid by March 25th    |
| B. Members | \$60.00 If paid after March 25th |
3. Annual fees are to be paid fifteen (15) days prior to the first rodeo in which the contestant wishes to compete as a member.
  4. Memberships must be purchased prior to June 1. There will not be any memberships sold after June 1. If a contestant hasn't purchased a membership by June 1, they will only be able to enter as a non-member.
  5. Contestants under the age of 18 shall include a copy of their birth certificate, a notarized release, and an application form to join the Association, all of which are to be kept on file with the Secretary. Only one birth certificate is needed on file. All contestants over the age of 18 shall include a notarized release and an application form. These application forms will be available from the Secretary at any time.
  6. Each contestant is responsible to notify the Secretary if a change of address occurs, or if any information differs from that given on the Application.

7. Non-members may compete at a sanctioned rodeo as long as the contestant pays the \$50.00 non-member fees in addition to all other rodeo & entry fees, and submits a notarized release for each rodeo. No points will be awarded to a non-member. Non-members are eligible for cash payout only. Non-members can join the GSRA after competing as a non-member, however, contestants are not eligible for points for any rodeo in which he/she competes as a non-member. Contestant has to be a member to compete at finals. Contestant must compete as a member in a minimum of two rodeos to compete at finals.
8. \$150 mandatory Sponsorship per paid member to be paid by June 1<sup>st</sup>. Non-paid fees will result in the ineligibility to compete the remainder of the season.

## SECTION 2. POINT SYSTEM

1. One of the purposes of the GSRA is to establish a point system to determine the GSRA Champion Cowgirls & Cowboys and to establish a set rule as to the division of prize money & points.
2. In order for point to count for the year-end All-Around award, a contestant must first place in a minimum of two events during the current calendar year. Prize money and points shall be awarded and divided in the following ways:

1 <sup>st</sup> place = 18 pts.	4 <sup>th</sup> place = 9 pts.
2 <sup>nd</sup> place = 15 pts.	5 <sup>th</sup> place = 6 pts.
3 <sup>rd</sup> place = 12 pts.	6 <sup>th</sup> place = 3 pt.

A. Points are always split six (6) ways. In the event less than 6 contestants qualify, then the qualifiers will receive the standard percentage for their placing and any points left over shall be considered unearned, and be forfeited.

B. If a non-member places at a rodeo, the points for that placing are forfeited and no member assumes them.

C. Points for the two-day finals rodeo will be awarded as follows:

<p>1<sup>st</sup> Place =      18 pts. For the 1<sup>st</sup> go                                   18 pts. For the 2<sup>nd</sup> go                                   18 pts. For the average.</p> <p>2<sup>nd</sup> Place =      15 pts. For the 1<sup>st</sup> go                                   15 pts. For the 2<sup>nd</sup> go                                   15 pts. For the average</p> <p>3<sup>rd</sup> Place =      12 pts. For the 1<sup>st</sup> go                                   12 pts. For the 2<sup>nd</sup> go                                   12 pts. For the average</p>	<p>4<sup>th</sup> Place =      9 pts. For the 1<sup>st</sup> go                                   9 pts. For the 2<sup>nd</sup> go                                   9 pts. For the average</p> <p>5<sup>th</sup> Place =      6 pts. For the 1<sup>st</sup> go                                   6 pts. For the 2<sup>nd</sup> go                                   6 pts. For the average</p> <p>6<sup>th</sup> Place =      3 pts. For the 1<sup>st</sup> go                                   3 pts. For the 2<sup>nd</sup> go                                   3 pts. For the average</p>
---	---

- If there is a tie for the year-end All-Around award or event awards, the contestant with the most money awarded (in all events in the contestant's division for the all-around award and in that specific event in the case of an event award) shall be determined the winner.

#### CASH PAYOFFS (PERCENTAGES)

<u>(Entered)</u>	<u>(Places Paid)</u>	<u>(Entered)</u>	<u>(Places Paid)</u>	<u>(Entered)</u>	<u>(Places Paid)</u>
1 to 2 Contestants	(1)	11 to 15 Contestants	(4)	21 & Over Contestants	(6)
Pot *100% = 1 <sup>st</sup> Place		Pot *40% = 1 <sup>st</sup> Place		Pot *29% = 1 <sup>st</sup> Place	
		Pot *30% = 2 <sup>nd</sup> Place		Pot *24% = 2 <sup>nd</sup> Place	
3 to 5 Contestants	(2)	Pot *20% = 3 <sup>rd</sup> Place		Pot *19% = 3 <sup>rd</sup> Place	
Pot * 60% = 1 <sup>st</sup> Place		Pot *10% = 4 <sup>th</sup> Place		Pot *14% = 4 <sup>th</sup> Place	
Pot * 40% = 2 <sup>nd</sup> Place				Pot *9% = 5 <sup>th</sup> Place	
		16 to 20 Contestants	(5)	Pot *5% = 6 <sup>th</sup> Place	
6 to 10 Contestants	(3)	Pot *34% = 1 <sup>st</sup> Place			
* 50% = 1 <sup>st</sup> Place		Pot *27% = 2 <sup>nd</sup> Place			
Pot * 30% = 2 <sup>nd</sup> Place		Pot *20% = 3 <sup>rd</sup> Place			
Pot * 20% = 3 <sup>rd</sup> Place		Pot *13% = 4 <sup>th</sup> Place			
		Pot *6% = 5 <sup>th</sup> Place			

#### FOR JUNIORS AND SENIORS

- Total pot money shall be awarded according to the number of contestants entered in that event.
- In the event qualifying places are not filled in an event, drop to the next payoff split. (EXAMPLE: Only 5 girls qualify out of 25 contestants, figure payoffs for 5 places paid, etc.)

#### FOR MINI MITES AND PEE WEES

- Total pot money shall always be paid six (6) places.
- See Rule #2 for Juniors and Seniors when less than 6 contestants qualify.

#### GENERAL PAYOFF RULES

- All money in pot shall be awarded.
- In the event only one contestant qualifies in an event, he/she shall receive 100% of the pot.
- In the event there are no qualifiers in an event, the Association shall keep only the arena fee, stock charge, or other specified amounts paid in and above the regular entry fee and pay back ground money to all contestants in that event.

#### SECTION 3: GENERAL CONTESTANT RULES

- Contestants may move up one or more age division and compete in an event only if the event is not offered in their own division. They will compete for money and their points will count for year-end event awards. Points earned outside of the contestant's division will not count toward year-end All-around awards.

2. Any contestant may lose points or be suspended or both, from the Association for any of the following offenses:
  - (a) The issuance of bad checks (having any fees paid by a check that is returned for insufficient funds, account closed, etc.) will result in a loss of all points previously acquired and suspension until the returned check plus a \$25.00 returned check fee are paid with good funds. Cash or cashier's check must be used to pay entry fees for the remainder of the year in which any check issued is returned.
  - (b) Non-payment of entry fees.
  - (c) Attempting to fix, threaten, bribe, influence, harass or coerce the judges at any time between opening and closing times of a rodeo, in or out of the arena. Violators shall be reported to the Arena Director by the judge (s) involved.
  - (d) Having conduct or speech of any kind detrimental to the best interest of the G.S.R.A. or the sport of rodeo.
  - (e) Fighting or quarreling in the arena.
  - (f) Failure to abide by or disobedience of Articles and Rules of the Association.
  - (g) For all rules and those not covered above, the Board of Directors will be called in to make the final decision and/or fall back on High School Rodeo rule book.
3. All contestants shall assist in keeping the arena clear, by staying out of the arena except when contesting or assisting.
4. The decisions of the judges, flagmen, and timers hired by the Association shall be final. No contestant may talk to a judge or timer while an event is going, unless to point out a discrepancy. Questions may be addressed to the judge or timer no sooner than at the end of that event. In case of a question of a judge ruling, the representative/contestant must approach the event director and the event director in turn sees the judge for a final decision. (See Section 5, Protest #1)
5. All contestants are required to read the rules carefully, particularly those relating to the contests or events in which they are entered. FAILURE to understand the rules will not be accepted as an excuse.
6. There shall be no limit to the times a horse can be ridden by different contestants in any one event, the only exceptions being in Barrels and Poles, Junior and Senior divisions (see Event Rules, (1) Cloverleaf Barrels, rule #6 & (2) Pole Bending, rule #6).
7. If numbers are furnished by the Association, contestants must wear them on the back of their shirts so as to be visible to the judges, timers, and spectators. The penalty for not wearing numbers may be disqualification.
8. Contestants must wear Western Attire; western hat, long-sleeve shirt tucked in with collar; western boots and trousers in the arena during their performance. Shirt sleeves may not be rolled up in the arena. Violators of these rules will be disqualified upon the discretion of the judges. The Western Attire rule does not apply to non-contestants or to those assisting in the arena. Contestants must enter the arena with their hat on. The roping box is to be included in the area defined as the arena. A 5 second penalty will be assessed to a contestant entering the arena who loses their hat prior to entering past the gate.



9. All contestants shall be ready to compete when called upon. Unless other arrangements have been made by the contestant with the Arena Director, Secretary, or Judges -prior to the event they are competing in, contestant may face possible disqualification by the judges.
10. Contestants must be on hand to answer call of the Arena Director and must comply with all other rules of the Association for each particular contest or exhibition held under the auspices of the G.S.R.A. When, in the opinion of the Arena Director, sufficient number of contestants are present for an event, there will be no delay because others are not present.
11. The Secretary (with the approval of the Board of Directors) reserves the right to refuse the entry of any contestant who has violated the general rules.
12. To be eligible to compete in the Rodeo Finals, a contestant must compete in at least two rodeos during the calendar year.
13. The Rodeo Finals shall consist of two (2) go-rounds and an average. Contestants must enter both go-rounds regardless of whether or not they compete in both. Payoffs will be equal in each go-around and the average, unless there is added money specifically designated to the average payout.
14. All entries are to be mailed to the Secretary with a check or money order and must be post marked 15 days prior to the rodeo. Entries may be hand delivered to the Secretary 15 days before the rodeo. Entries later than this will not be accepted. Checks will be held until the first week following the rodeo.
15. Earnings will be mailed to the contestant at the discretion of the current year's Treasurer.
16. Checks from the Association are void if not cashed within sixty (60) days from the date issued.
17. There will be no exhibition runs.
18. Mini Might & Pee Wee divisions are allowed to have help into the arena but not past the start line. If helper passes the start line it will result in a no time. If the helper passes the plane of the gate in the Junior and Senior divisions, it will also result in no time. The roping box shall be considered as the arena for the application of this rule and assistance to Mini Mite & Pee Wee contestants to set their horse while in the box is allowed, however, no contact shall be made with the contestant or horse following the contestant's call for their livestock.
19. For events with partners, if one contestant is absent or unable to complete, the Secretary (or another Officer if the Secretary is not present) shall draw a replacement partner. The draw shall be from contestants that are present, able to compete and not already entered the maximum allowed entries. The drawn contestant must then accept the draw by paying the entry fee in which case the go will be eligible for payout and points for both competitors. If the drawn partner declines, the Secretary shall continue to draw until an eligible contestant accepts the draw and enters. If no such contestant is present, a partner will be drawn from the competitors present that have already entered the maximum allowed entries. The drawn contestant may either accept or decline the draw. If accepted, the drawn replacement contestant will not be required to pay the entry fee and will not be eligible for points or payout, however, the original contestant for whom the replacement partner is drawn is still eligible for payout and points. If declined, another draw will be made until a competitor accepts the draw. Any replacement partner must be drawn by the Secretary or substitute officer and may not be hand-picked by the contestants.

#### SECTION 4: CONTESTANT DISQUALIFICATION'S

In order to maintain a good image in a youth organization, any persons assisting with the rodeo, in any capacity, shall not be drinking any alcoholic beverages between openings and closing times of the rodeo. The G.S.R.A. officials (judges and Board of Directors) may withdraw any contestant's name and entry, disbar them from any and all events, and withhold any money due them for violation of the governing rules of the Association, or for any of the following offenses:

1. Violating the western dress code.
2. Not being ready to compete when called.
3. Being under the influence of liquor or drugs.
4. Rowdiness, quarreling or fighting in the actual domain of the arena at any time.
5. Mistreatment of stock.
6. Altercation or quarreling with the judges or officials. All judge's rulings are final.
7. Failure to give assistance when requested to do so by the Arena Director, or for any reason deemed sufficient by the Association rodeo.
8. Cheating or attempting to cheat. This carries the penalty of loss of all points acquired up to that time and suspension for not less than one year.
9. Conduct or speech of any kind detrimental to the best interest of the Association or the sport of rodeo.
10. Refusing to compete in position drawn by the Secretary, unless other arrangements have been made with the Secretary.

#### SECTION 5: PROTESTS

As stated in the purposes in the Articles of Incorporation, it is this Association's aim to protect its members against unfairness and to provide a uniform set of rules for all contestants. In order to protect our contestant's personal rights, each contestant is entitled to a private hearing with the judges and Board of Directors.

1. In the event a contestant has a protest, the contestant and the representative, if they choose to have one, shall go to the Event Director and register their complaint immediately. The Event Director shall relay the protest to the judge and his decision shall be final on all protests. The protest must be lodged during or no later than immediately after that event in question.
2. If after the Event Director relays the protest to the judges, the problem cannot be immediately resolved, the protest will be taken to the Board of Directors.
3. The judges shall decide whether the protest is important enough to warrant a short delay to talk with the Board of Directors, or if the decision can wait until after the rodeo. A majority of three Directors shall decide.

#### SECTION 6: YEAR END AWARDS/BANK FUNDS

Year-end All-around awards will be awarded in each age division. High point event awards will be awarded relative to the number of contestants entered at the Finals. Contestants must compete in the Finals to be eligible for year-end awards.

1. Division of Funds.
  - a. The All-Around and high point event awards money will be determined by the amount of funds available from sponsorships and donations for the current year. Additional monies may be added to awards from the general fund if determined appropriate by the Board of Directors. Total awards money shall be distributed amongst each event based on the number of places receiving an award. (Refer to Article II, Section 2, cash payoff rules).
  - b. The All-Around award money can be used toward a saddle or a befitting award of the

recipient's choice.

- c. No unspent monies designated for awards shall be awarded in cash and will be returned to the general fund.

2. Year-end All-Around awards.

- a. An All-Around award shall be given in each age division. The All-Around winner in each division will be determined by the highest accumulation of points for the year in any two or more events. All points earned by a contestant, in any event offered in their age division, will count towards the All-around in that division.
- b. A Reserve All-Around award shall be given to the second highest accumulation of points for the year in any two or more events in that division.
- c. Rookie Awards: Awarded to one boy and one girl with the highest accumulation of points for the year in any two or more events in anyone's first year as a GSRA member.

3. Year-end High Point Event awards.

- a. High point event awards will be awarded relative to the number of contestants entered at the Finals. The Mini-Mite and Pee-Wee age groups will receive awards to 6<sup>th</sup> place. For the remaining age groups, year-end awards will be awarded according to the same schedule as the event payouts. The breakdown will be as follows:
  - 1 - 3 Entries at the Finals = 1 Award
  - 4 - 6 Entries at the Finals = 2 Awards
  - 7 - 9 Entries at the Finals = 3 Awards
  - 10 - 12 Entries at the Finals = 4 Awards
  - 13 - 15 Entries at the Finals = 5 Awards
  - 16 or more Entries at the Finals = 6 Awards.
- b. The decision to give more than 6 awards in any age division, will be at the sole discretion of the Board of Directors.

4. General Fund.

- a. Any monies left in the general fund at the end of the fiscal year, after determining any carryover for future expenses, will be added to the following years finals (to be split equally amongst all events - designated specifically to pay the average). In the event the amount held in the general fund exceeds \$10,000, or the amount determined by the Board of Directors, an additional sum of \$1,000 will be added to the following years finals (to be split equally amongst all events - designated specifically to pay the average), until the sum held in the general fund is reduced to below the maximum balance designated for the general fund.

5. Participation Awards.

- a. Contestant competing in the finals and not receiving awards in ANY event will be eligible for participation awards. Award will be determined by monies available.

Availability will come from the money distributed to each age group from the general fund or funds raised specifically for participation awards. The value of participation awards shall not exceed 1/2 of 5th place awards.

**ARTICLE III  
REGULATIONS FOR RODEO**

SECTION 1: CONDUCT OF RODEO

1. The management assumes no responsibility or liability for injury or damage to the person, property, stock of any owner, contestant, or assistant. Each participant by the act of his/her entry, waives all claims against the Association and its management for any injuries he/she or his/her property may sustain.
2. Any rodeo with ground rules contradictory to or in addition to Association rules must hold a general meeting in the grandstand or center of the arena to inform all contestants before the rodeo starts. Announcer shall be instructed to relay these changes and/or additions over the loud speaker at least twice before a rodeo begins. Arena Director and judges shall be present during this meeting to clarify any questions contestants may have.
3. The Board of directors will set the price for salaries of judges, timers, or announcers, but the Association expects to pay fair salaries in keeping with rodeo size and Association budget.

SECTION 2: DRAWING OUT AND ENTRY FEE REFUNDS

1. The Association shall not be responsible for returning a contestant's entry fee if she/he has contested in an event even once during the rodeo, however, if the contestant is entered in any other event in which the contestant is unable to compete, the entry fee may be refunded.
2. There will be no drawing out after positions are drawn, unless contestant has a doctor's or vet release. The Secretary must be notified by an injured contestant or parent before the first time the contestant is scheduled to compete.
3. If in the opinion of the judges a contestant is unable to compete in a particular event because of injury, the contestant may withdraw, but this does not prevent the contestant from competing in other events in which he/she is entered.
4. All entry fees must be paid in advance by mail or prior to competing or the entry will be void.

**ARTICLE IV  
REGULATIONS FOR OFFICIALS**

SECTION 1: SELECTION OF JUDGES AND TIMERS

1. All timers and judges shall be chosen by the vice-president and approved by the Board of Directors. Names may be added or deleted by a majority vote of members present at any general meeting.

SECTION 2: ARENA DIRECTOR

1. The duties of the Arena Director are to locate, inspect, assign arena and ensure that the rodeo is run in the smoothest possible manner. If no Arena Director is elected these duties shall be

the responsibility of the President.

2. It shall be the Arena Director's and Board of Directors responsibility to decide if a rodeo should be called off, delayed or resumed when bad weather occurs.

### SECTION 3: TIMERS

1. Timers for the go-around may not be changed after the first performance except in case of sickness or injury, or by request of two (2) or more Association Officials, because of timer's incompetence.
2. Timers must work from the same position in all performances of that go-around.
3. Timers should have prior experience and be positioned at a place that facilitates good communication with the Arena Director, Judges, and Announcer.
4. Timers shall be responsible for keeping a timer's sheet and recording times, including all penalties added on, which is provided for them by the Secretary.
5. All rodeos are required to use watches or digital timers in hundredths of a second. There shall be two timers for all events and times will be averaged.

### SECTION 4: JUDGES

1. Judges must read the G.S.R.A. Rule Book to familiarize themselves with all of the rules and potential disqualifications.
2. Tie Down is chute run. They will not be drawn.
3. Timed event judges will not flag a contestant out until their time is recorded. The judge is to flag the time, and then flag the contestant out if the run is not legal.
4. Judges must remain available to the Secretary for a short time after the rodeo ends in case any questions arise.

### SECTION 5: JUDGING RULES - TIMED EVENTS USING BARRIER

1. A ten-second penalty will be added for breaking or beating the barrier. In all timed events, a barrier will not be considered broken unless the ring drops within ten (10) feet of the post. Barrier equipment must be inspected by the judges before each timed event. If equipment is faulty, it must be replaced. Should the barrier break at any point other than designated breaking point, decision is up to the barrier judge. If the contestant obviously beats the barrier, but the staples are pulled or the barrier rope is broken and string unbroken, the barrier judge may assess a ten second penalty, otherwise this circumstance will not be considered a broken barrier.
2. Once the score line has been set in timed events, it will not be changed at that rodeo, nor can the length of the box be changed.
3. Animal is to be flagged when crossing the score line barrier or barrier equipment.
4. The flag judge shall be sure nobody tampers with the barrier or barrier equipment.
5. If automatic barrier does not work, but time is recorded, contestant will get time, but there will be no penalty for broken barriers. Stock will not be brought back if stock is missed.
6. If automatic barrier does not work and official time is not started, contestant will get stock back if stock is qualified on in the field, entitling contestant to a rerun without penalties.

7. If automatic barrier does not work, and stock is brought back, contestant must take same animal (if drawn for) over, during or immediately after the same performance.
8. Calf belongs to contestant when he/she calls for it, regardless of what happens, with the following exceptions.
  - (a) If the calf gets out of the arena, flag will be dropped and the roper gets the calf back lap and tap with the time added which was taken when the calf left the arena plus any barrier penalties.
  - (b) In cases of mechanical failure.
  - (c) If in the opinion of the line judge contestant is fouled by barrier, contestant shall get his/her calf back, providing contestant declares him/herself by pulling up.
9. In calf roping, horse must clear the box before the loop is thrown. Judge will start watch when roper signals for tie if roper's rope had come off calf, or when roper has remounted and his horse has taken one step forward.
10. Rope will not be removed and will remain slack until field judge has passed on the tie.
11. Flagger must watch calf during the six (6) second period.
12. If horse excessively drags the calf after roper has dismounted, field judge may stop horse.
13. If a calf kicks loose, the judge will stop watch and check time to determine if the tie was legal.
14. Untie man must not touch calf until judge has passed on tie.
15. Time is to be taken between two flags.
16. Contestant will be disqualified for abusive treatment of calf or horse.
17. Roping box is considered part of the arena. If calf runs into the roping box it will still be considered in play, and will not be considered as escaping the arena.
18. Timed event judge will not flag contestants out until time is recorded. Judge is to flag time, then flag contestants out if run is not legal.
19. See also event rules for Calf Roping Section 12.

#### SECTION 6: JUDGING RULES - TIMED EVENTS

1. Timed events will be timed with one electric eye and two (2) hand held battery power digital watches in hundredths shall be used, with the time indicated by the electric eye timers, or, if necessary, the average of the watches used by the official timers to be the official time.
2. Digital hand held watches to be back up time. When both the digital clocks malfunction and no time was recorded from digital watches, contestant will be given a rerun at a time designated by the Judges and Arena Director, plus any penalties incurred in the original run.

3. Contestant will be allowed legitimate time from the time he/she enters the arena gate until his/ her time starts by Field Flagger or electric eye. Contestant may enter the arena at the speed of his/her choice.
4. Arena gate will be closed immediately after he/she enters the arena, and kept closed until pattern is completed and contestant's horse is under control.
5. If contestant's horse breaks timer light, by backing through before starting pattern, time will be considered started. If horse re-crosses starting line at any time before the pattern is completed, contestant will receive no time.
6. When field flagger is used, time is to start when a horse's nose crosses line, both start and finish. If animal at any time during the course of the run crossed the start/finish line then time is finished and pattern is broken and contestant receives a no time. Judge will not flag contestant out until time is recorded. Judge is to flag time, and then flag contestant out if run is not legal.
6. Contestant may hold up or steady a barrel or pole he/she is rounding as long as the barrel or pole has not been knocked over completely.
7. The starting line (flagging position), barrel and pole locations must be marked permanently for the entire rodeo.
8. Western type equipment must be used. Use of a hackamore or other types of bridles is the optional choice of the contestant. Judges may prohibit the use of bits or equipment that he may consider severe.
9. Arena and Event Directors together will make the decision as to when to rake around the barrels and poles. It will be announced to the contestants at rodeo prior to the event.
10. No reruns will be given due to faulty or broken equipment furnished by the contestant.
11. All divisions shall use the same rules in the barrel racing and pole bending.

#### SECTION 7: SECRETARY

1. The Secretary's name, address and phone number shall be posted in newsletter preceding each rodeo and shall specify times when entries may be phoned or mailed.
2. All entries shall close at midnight on the fifteenth day preceding each rodeo.
3. No one except the Secretary will be allowed to accept entries.
4. Positions must be drawn in all events for Finals. The order is reversed for the second day. Contestants using the same horse may be split.
5. Contestant is privileged to see the records of all contestants in any event, in which they take part, at the end of each go-around.
6. Secretary shall make two copies of all timed event score sheets, one master sheet and one timer sheet. Timer's sheet shall be checked with master to ensure all times and penalties are accurate and kept with final records.
7. Master score sheets will not be removed from the office, except with the approval of the Secretary.
8. Rodeo results must be audited within two days after each rodeo to check for errors (by either

the Secretary or Points Keeper).

9. A complete go-around must be finished before any contestant can compete in a second go-around.

### SECTION 8: FIELD FLAGGER

1. In any timed event if an animal escapes from the arena, the flag will be dropped and watches stopped. Contestant will get animal back with lap and tap start and time already spent will be added to time used in qualifying. If time is not recorded, the decision of the flag judge shall be final concerning reruns.
  - (a) If rope is on animal, roper will get animal lap and tap with rope on it in chute.
  - (b) A field flag judge must ask contestant if they want a second loop. Once a contestant has been flagged out, she/he will receive no stock back.
2. Neither the timers, barrier judge, nor field judge may be changed during the course of a go-around, except in case of sickness, injury or incompetence and then by the request of two (2) or more Association Board of Directors.
3. The decision of any judges, flagmen or timers will be final and no protests by contestants will be permitted except through an Event Director.
4. Judges may be required to keep a record of all penalties, no times and any changes of working order of contestants in all events they are judging. After each performance, judges will check their records with the Rodeo Secretary and make the necessary changes if error has occurred.

## **ARTICLE V REGULATIONS FOR EVENT DIRECTORS**

Each Event Director is responsible for his or her event at each approved G.S.R.A. rodeo and shall appoint someone to assume his or her duties in case of absence.

Event Directors shall be identified at each rodeo so contestants will be familiar with them in case of problems or questions.

Event Directors are responsible for being available during their prospective events so contestants may contact them in case of problem/protest. Event Directors will act on behalf of the contestant and present the problem to the judges no sooner than the end of that event. The final decisions in all cases are up to the judges.

1. **BARREL DIRECTOR:** Responsibilities are to include but not limited to ensure that barrels are available and in a safe condition. Utilize a speedy system for setting and resetting barrels. Additional duties include:
  - (a) Setting up barrels. Both ends of barrels will be intact. Barrels are not to be used for stands for electric eyes. Barrels are to be setup in a cloverleaf pattern. There will be a minimum of 75' allowed for stopping, from starting line in barrels back to arena fence. All barrels must be twenty (20) yards or further apart. Arena conditions will determine spacing of anything further than 20 yards. There must be a minimum of twenty (20) feet from the barrel to the arena fence. The front two barrels shall be 20 yards (60 feet) from the starting line. The maximum distance between the two front barrels shall be thirty (30) yards (90 feet) arena conditions permitting. The maximum distance between the back barrel and the front two



barrels will be 105 feet arena conditions permitting.

- (b) Setting up electric eyes. Markers are to be put up for electric eyes. These are to be placed no closer together than the width of the first two barrels and for the electric eyes to be centered on pattern for each performance.
  - (c) Mark barrel pattern, working with the Arena Director on the arenas with questionable sizes.
  - (d) Mark line on fence for flagman.
  - (e) See that rakes are available with people to man them. Designate equal spacing between contestants for arena to be raked to insure fairness for each contestant.
  - (f) Designate people to aid in getting barrels in and out of the arena.
  - (g) Determine with Arena Director the number of contestants to run before raking.
2. POLE BENDING DIRECTOR: Responsibilities are to include but not limited to ensure that poles are available which are even and in good working condition.
- (a) Mark pole pattern and utilize a speedy system for setting and resetting poles, such as buried ropes or knotted rope. There shall be a minimum of 75 feet allowed for stopping, from starting line in poles back to arena fence. The distance from the starting line to the first pole shall be 21 feet and spacing between poles shall be twenty-one (21) feet apart. End pole must be twenty (20) feet at least from the fence. Poles shall be set on top of the ground, six feet in height, and with no base larger than fourteen (14) or less than twelve (12) inches in diameter. Poles must be set in a straight line.
  - (b) See that rakes are available with people to man them. During the event it will be set up to drag around the poles at regular intervals to assure equal opportunities for each contestant.
  - (c) Starting line and line on fence for flag judge are to be marked.
  - (d) Designate people to aid in setting and resetting the poles.
  - (e) Determine with Arena Director the number of contestants to run before raking.
3. GOAT DIRECTOR: Responsibilities are to include but not limited to ensure that goats are available in the proper size and number for Goat Tying and Goat Flanking.
- (a) All goats in each respective event should be of uniform size and weight of 50 to 70 lbs. per goat. Sharp horns shall be tipped.
  - (b) All goats are to be tied down three times before the rodeo.
  - (c) Goats will be changed after the number of contestants determined by the Arena Director and the Goat Director. Otherwise goats will only be changed in case of injury.
  - (d) Arena specifications will be the same as in Goat Tying as they are in Goat Flanking.
  - (e) Goats will be tied to stakes. See that stake, ropes, collars and a hammer are provided.
  - (f) Designate people to aid in getting goats in and out of arena, holding goat properly and seeing that competition area is not cluttered with unnecessary personnel. Goat handlers may not be goat tying contestants and must stand directly behind goat. Judges and directors will position themselves so they are able to have a clear view of the goat, rope, and horse.

- (g) There should be at least a 15-yard starting line. Starting line will be 100 feet from stake.
- (h) The goat should be tied to a stake with a rope ten feet in length. Stake should be completely under the ground so that no part of it is visible or above ground.
4. BREAKAWAY DIRECTOR: Responsibilities are to include but not limited to ensure that the proper equipment is available for barrier and that chute is in workable condition. Same responsibilities apply to Breakaway Director as apply to Calf Roping Director. Also including:
- (a) The Breakaway Director will provide breakaway string.
- (b) The Breakaway Director will inspect all ties before contestant enters the box.
5. TEAM ROPING DIRECTOR: Ensure that the proper equipment is available for barrier and that chute is in working condition. Same responsibilities apply to Team Roping Director as apply to Calf Roping Director.
6. BOYS' FLAG DIRECTOR: Ensure that barrels, buckets with grain or litter, and flags are available. To designate people to replace flag and reset barrels.
7. CALF ROPING DIRECTOR: Responsibilities are to include but not limited to ensure that the proper equipment is available for barrier and that chute is in workable condition. Additional responsibilities include:
- (a) Pigging string will be used for securing animals
- (b) Cattle neck ropes on calves must be tied with string, zip ties or rubber bands.
- (c) No metal snaps or hardware shall be used on cattle neck ropes in the calf roping event.
- (d) Adjustable slide shall be used on all cattle neck ropes for cattle used in calf roping event.
- (e) An automatic barrier must be used. Director is responsible to change barrier string when- ever it may have been weakened, or on request of the next contestant. Records will be kept of the length of the barrier trip rope each performance to assure the same start for contestants each performance. If equipment is faulty it must be replaced.
- (f) Director will make sure that nobody can stand close enough to barrier or barrier equipment to tamper with it.
- (g) Height of barrier in timed events shall be from 32" to 36" measured at the center of the box.
- (h) A ten-foot tape must be on hand to measure score line and check 10' barrier ring rule.
- (i) Adjusting length of barrier trip rope will be accomplished only by tying knots in the rope on either end.
- (j) Arena conditions will determine the score, length of score to be set by arena director and timed event judge.
- (k) This event will not be conducted with an open catch pen gate at any rodeo.
- (l) Calves will be uniform in weight and breed.
- (m) Animals used for this event should be inspected and objectionable ones eliminated.

- (n) If after one go-round has been completed, a fresh calf has to be used; the calf must be roped and tied before the drawing, but if extra calves have been roped at that rodeo they will not be considered fresh.
- (o) If for any reason a calf must be called back, it will never be brought back alone. At least several heads will be brought back together. The arena director will make decisions about re-penning animals.
8. DUMMY ROPING DIRECTOR: Insure that roping head is available. Mark roping lines. Obtain scorekeeper, select a suitable area outside of arena, and take scores to timers to be announced.
  9. FIGURE 8 DIRECTOR: Make sure the poles are set correctly. People are available to set up poles.
  10. CALF/STEER/COW RIDING DIRECTOR: Responsibilities are to ensure that stock is available and in a safe & suitable condition. Director to chute load stock and assign contestant based on draw order. Director to inspect any equipment for the safety of rider and stock and to have designated people to aid in getting stock out of the arena after each ride.
  11. STEER WRESTLING DIRECTOR: Responsibilities are to include but not be limited to ensure that the proper equipment is available for the barrier and that the chute is in workable condition. The same responsibilities apply to Steer Wrestling Director that apply to Calf Roping Director. Additional responsibilities include:
    - (a) Ensuring that the contestant competes on the steer drawn for him.
    - (b) All stock has been thrown a minimum of three (3) times prior to the rodeo.
    - (c) Adequate help is designated and available to load steers into chute and get steers in and out of the arena.
    - (d) Ensure that steers are of consistent size and not more than 550 lbs.
  12. CHUTE DOGGING DIRECTOR: Same responsibilities as for Steer Wrestling also including:
    - (a) The score line is set 10' parallel from the closed bucking chute.

## EVENT RULES

### ARTICLE 1

#### SECTION 1: CLOVERLEAF BARRELS SEE ALSO REGULATION DIAGRAM PAGE 32

1. Time limit for this event will be one minute (60 seconds).
2. The contestant is allowed a running start. If the gate is centrally located, contestant must keep forward motion toward the first barrel. If a side or corner gate is used, a single spin or pivot is acceptable in either direction or by the Arena Directors approval. Failure to comply will be a no time. Contestant must be mounted when entering the arena.
3. The contestant may start her pattern either to the right or the left barrel. If she starts on the right barrel there will be one right turn and two left turns around the barrels. If she starts to the left there will be one left turn and two right turns around the barrels.
4. Touching the barrel is permitted by horse or contestant.

5. Knocking over a barrel is a five (5) second penalty, per barrel. If the barrel is knocked over and resets itself on its opposite end the (5) second penalty will be assessed.
6. Not following the cloverleaf pattern will result in a no time.
7. For the Junior and Senior divisions, a barrel horse shall not be ridden by more than one contestant in this event at any one rodeo.
8. See also: Article IV Section 6: JUDGING RULES - TIMED EVENTS and Article V Regulations for Event Directors 1. Barrel Director for additional rules and regulations.

**SECTION 2: POLE BENDING SEE ALSO REGULATION DIAGRAM PAGE 33**

1. Time limit for this event shall be one minute (60 seconds).
2. The pole bending pattern is to be run around six (6) poles. The rider may start either to the right or left of the first pole and then run the length of the poles, turn around the last pole and weave back and forth through the poles to the last pole, round the end pole and weave back and forth through the poles to the end, round the pole and run straight down the length of the poles to the finish line.
3. Touching or steadying poles by either horse or rider is permitted.
4. The penalty for knocking over a pole is five (5) seconds per pole.
5. Breaking the pattern will result in a no time.
6. For the Junior and Senior divisions, a pole horse shall not be ridden by more than one contestant in this event at any one rodeo.
7. See also: Article IV Section 6: JUDGING RULES - TIMED EVENTS and Article V Regulations for Event Directors 2. Pole Director.

**SECTION 3: GOAT TYING (Senior Girls, Junior and Pee Wee Girls and Boys)**

1. Time limit for this event will be one minute. **(60 seconds)**
2. The contestant must be mounted on a horse and must ride from the starting line to the goat, dismount from his/ her horse, and throw the goat by hand.
3. If the goat is down when the contestant reaches it, goat must be elevated so that at least 3 feet are dangling above the ground, and goat must be re-thrown. Cross and tie any three legs together with a leather thong, pigging string, or rope and stand clear of the goat.
4. Legs must remain crossed and tied for 6 seconds after completion of tie. To qualify as a legal tie, there will be one or more wraps, and half hitch, hoey, or knot. Completion will be acknowledged by throwing of hands.
5. Time will start when contestant crosses the starting line and end when signal is thrown.
6. Contestant will receive a no time for touching the goat or tie after signaling completion.
7. Contestant must step back three (3) feet from the goat before judge starts six (6) second time limit for the goat's legs to remain crossed and tied. If contestant gets the rope that holds the goat wrapped around his/her leg, the contestant may ask the judge if he/she can remove it. After getting permission from judge, removing the rope and stepping back three (3) feet his/her six (6) second time limit will start.

8. If the contestant runs over the goat or rope with his/her horse while mounted, or if the contestant's horse comes in contact with the goat or rope at any time, a ten (10) second penalty will be assessed to contestant.
9. If goat should breakaway because of the fault of the horse while contestant is mounted he/she will receive a no time. A contestant is still mounted until both feet are on the ground.
10. Pee Wee Boys Goat Tying contestants must use a pigging string.

#### SECTION 4: BOYS FLAG RACE

1. The time limit for this event is sixty (60) seconds
2. A standard course should be set whenever possible.
  - (a) Barrels to be 100 ft. from the starting line.
  - (b) Barrels placed 60 feet apart.
3. Five-gallon buckets will be set on 55 gallon barrels.
4. Buckets must be filled at least 2/3 with grain or cat litter.
5. Contestant may run course from the right to the left or left to right, in either case bucket on first barrel is contains no flag, bucket on second barrel contains flag.
6. Contestant is given flag at starting line, races to barrel with empty bucket, places flag, races to bucket containing flag, retrieves flag, and races back to finish line.
7. Contestant will be disqualified for:
  - (a) Knocking over a bucket or barrel.
  - (b) Crossing finish line without flag.
  - (c) Using the flag as a whip.
  - (d) Failing to place flag in first bucket.

See also: Article IV Section 6: JUDGING RULES - TIMED EVENTS and Article V Regulations for Event Directors 6. Boys Flag Director.

#### SECTION 5: GOAT FLANKING: (Mini Mite Boys and Girls)

1. Time limit for this event is sixty (60) seconds
2. The contestant must be mounted on a horse and must ride from the starting line to the goat, dismount from the horse, throw the goat by hand and signal completion by throwing hands in the air.
3. If the goat is down when the contestant reaches the goat, the goat must be re-thrown. All legs must be horizontal with the ground and at least one knee on the goat. Then contestant must signal completion, by throwing both hands in the air. Contestant must then stand clear of the goat.
4. If the contestant runs over the goat or rope with his/her horse while mounted, a ten (10) second penalty will be assessed to the contestant. After the contestant dismounts his/her horse, the Goat Director or person(s) assigned by the Goat Director may catch the contestant's horse to ensure safety, therefore, no penalty will be assessed if the contestant's horse comes in contact with the goat or rope after the contestant dismounts.
5. If goat should breakaway because of the fault of the horse while contestant is mounted he/she will receive a no time. A contestant is still mounted until both feet are on the ground.

## SECTION 6: DUMMY ROPING

1. Each contestant gets three (3) loops. Parents may help build loops and hand to contestant.
2. Must throw loops from behind starting line, 4  $\frac{1}{2}$  feet from roping head.
3. Must pull rope tight to score.
4. If the contestant steps on the line, he/she will receive no points for that try. Points will be determined as follows:
  - (a) 1 pt for half head (one horn and around neck)
  - (b) 2 pt. for neck catch
  - (c) 3 pt. for around horns only

See also: Article IV Section 6: JUDGING RULES - TIMED EVENTS and Article V Regulations for Event Directors.

## SECTION 7: BREAKAWAY ROPING

1. Time limits apply: Junior & Senior 30 seconds, Pee Wee 45 seconds
2. Contestants are only allowed to carry 1 loop.
3. Ropes are to be tied to the horn with a nylon string and may not be run through bridle, tie down, neck rope or any other device. A knot must be at the end of the rope with the string tied at the knot. There will be no tail. A white flag that is visible to the flagman or judge must be attached at the knot end of the rope.
4. No loops are to be rebuilt.
5. Catch-as-catch-can rule applies after the loop has passed over the calf's head.
6. Rope must be released from the contestant's hand to be a legal catch.
7. The contestant will receive a no time if he/she breaks the rope away from the saddle horn by hand. However, if the rope should dally around the horn, the contestant can ride forward, undally the rope stop his/her horse to make the rope breakaway.

See also: Article IV Section 5: JUDGING RULES - TIMED EVENTS USING BARRIER and Article V Regulations for Event Directors 4. Breakaway Director.

## SECTION 8: STEER WRESTLING: REFER TO NATIONAL HIGH SCHOOL RODEO RULEBOOK

See also: Article IV Section 6, Judging Rules - Timed Events Using Barrier and Article V—Regulations for Event Directors 11. Steer Wrestling.

## SECTION 9: CHUTE DOGGING:

1. Contestant gets in the bucking chute, beside the steer, right hand in front of or behind right front shoulder.
2. The score line will be 10' in front of the closed bucking chute and after the contestant calls for the chute gate to be opened, the contestant must keep his right hand in front of or behind right front shoulder until the steer's nose crosses the score line or a ten (10) second penalty will be added. Contestant will be disqualified if the steer is thrown before crossing the score line.
3. The judge will flag the start when the steer's nose crosses the score line and time stopped

only when the steer is thrown lying flat on its side, or on its back with all four feet and head straight.

4. A straightaway chute may be used in lieu of a bucking chute. The chute must have a gate with at least thirty-six inch (36") clearance. It should be at least six foot (6') in length. Ideally it will also have a side entrance gate for dogger to enter.
5. See also: Article IV Section 6, Judging Rules - Timed Events and Article V— Regulations for Event Directors 12. Chute Dogging.  
REFER TO THE NATIONAL HIGH SCHOOL RODEO ASSOCIATION RULEBOOK FOR ADDITIONAL RULES.

#### SECTION 10: STEER DOBBING:

1. The contestant receives a no time if the steer travels 3/4 down arena. The catch pen gate will be open.
2. A barrier is required. The neck rope must be off of the steer before the steer can be dobbed.
3. Contestant may have an assistant to push the steer. If no assistant, the arena director may appoint someone to push the steer.
4. A hazer is required. An adult is legal.
5. Steer belongs to contestant when he calls for it, regardless of what happens. See section 7: judging rules- timed events using barriers for exceptions.
6. The baton shall be a bat with a ball glued on the end of it. The ball is then dipped in chalk and handed to the contestant when riding in the box before the barrier is hooked. Hitting the horse with the bat in any way will result in disqualification.
7. The dobber is to dob the steer anywhere on the left side (top center will count as left).
8. To stop the time, the contestant must raise the bat above his shoulder after dobbing the steer on the hip. Failing to raise the bat to signal time will result with a no time.
9. Hitting the horse with the bat in any way will result in disqualification.

#### SECTION 11: CALF TYING

1. Calf will be tied from post or chute. Time starts when contestant's hand leaves post/chute and stops when both hands clear the string. Length of rope must be the same for everyone.
2. Thirty (30) second time limit.
3. Calf must be in standing position with a designated tailer when contestant leave the post/chute. Tailer will release the tail when contestant touches calf.
4. Contestant must throw animal by hand and cross and tie any three legs.
5. Legal tie is at least two wraps around all three legs and a half-hitch or hooley with all legs crossed. A calf roping pigging string must be used.
6. If Contestants' hand is on animal when it falls, it is considered thrown.

7. Contestant may not touch animal after signaling their run is completed unless instructed by Judge. Doing so will result in a no time.
8. Tie must hold with three legs crossed for at least six (6) seconds. Time will start when contestant has stepped three feet from the animal.
9. The Judge will watch the animal during the six (6)-second period and will stop the watch in the event the animal gets free, using the time on the watch to determine if it was tied for the required length of time.
10. Calf must be switched every third run.

#### SECTION 12: SENIOR BOYS CALF ROPING

1. Time limit for this event will be 45 seconds
2. A neck rope must be used. Contestants must adjust rope and reins in a manner that will prevent the horse from dragging the calf.
3. Contestant's assistant may push out calves providing they are ready. If not, arena director will have worker to push calves.
4. Calf belongs to contestant when he calls for it, regardless of what happens. See Section 7: JUDGING RULES - TIMED EVENTS USING BARRIERS for exceptions.
5. Two loops will be permitted. If roper intends to use two loops, he must carry two ropes. No loops can be rebuilt.
6. Contestant cannot receive any assistance after crossing starting line.
7. Contestant must rope calf, dismount, go down the rope and throw the calf by hand. Cross and tie any three legs.
8. Pigging string must be used for securing animals.
9. Any catch is legal, catch as catch can rule.
10. If calf is down when roper reaches it, calf must be stood on at least three feet. (Calf must be elevated high enough that he could regain his feet) and calf must be re-thrown.
11. If roper's hand is on calf when calf falls, calf is considered thrown by hand.
12. Rope must hold calf until roper gets hand on calf.
13. To qualify as a legal tie, there shall be one or more wraps, and a half hitch or hooey (A hooey is a half hitch with a loop, the tail of the string may be partly or all the way pulled through). The tie must hold six (6) seconds, and three legs must remain crossed until passed on by the judge.
14. The tie must hold six (6) seconds, and three legs must remain crossed until passed on by the judge.



15. Six (6) second time will start when roper has remounted and his horse has taken one step forward.
16. If roper's rope comes off calf as roper starts to work with tie, the six (6) second time will start when roper signals for time.
17. Rope will not be removed and rope must remain slack until field judge has passed on tie.
18. No rerun will be given due to faulty or broken equipment furnished by contestant.  
See also: Article IV Regulations for Officials, Judging Rules for Timed Events using a Barrier. See also: Article V Regulations for Event Directors, Calf Roping Director.

#### SECTION 13: TEAM ROPING

1. Time limits will apply: Junior 45 seconds, Senior 30 seconds
2. Contestants may enter as 2 boys, 2 girls, or 1 boy & 1 girl on one team. No draws except to pair unmatched ropers entering the draw (contestants not entered in the draw or already entered twice will not be drawn for an unpaid additional go with an un-partnered contestant). Any remaining un-partnered contestant will be withdrawn & refunded their entry fee for this event.
3. A dally team roper may only enter twice at any rodeo.
4. Each contestant may only carry one rope. Each team is allowed two (2) throws in all.
5. Header will start behind barrier, and must throw the first loop at head.
6. Heeler must start from behind barrier line.
7. Time will be taken when steer is roped, both horses facing steer in line with ropes dallied and tight, horse's front feet must be on the ground. Ropers must be mounted when time is taken.
8. Roping steer without turning loose of the loop will be considered a no catch.
9. Roper must dally to stop steer or change steer's direction. Dally means to complete one turn around the saddle horn.
10. No tied ropes are allowed.
11. Steer must be standing up when roped by head or heels.
12. No foul catches can be removed by hand.
13. If steer is roped by one horn, roper is not allowed to ride up and put rope over other horn or head with his hands.
14. If heeler ropes a front foot or feet in the heel loop, this is a foul catch. Neither contestant may remove the front foot or feet from the loop by hand. However, should the front foot or feet come out of the heel loop by the time the field judge drops his flag, time will be counted.
15. There will be only three (3) legal head catches.

- a. Both horns.
- b. Half a head.
- c. Around the neck.

16. If Hondo passes over one horn, the loop over the other, the catch is illegal.
17. If the loop crosses itself in the head catch, it is illegal. This does not include heel catches.
18. Any heel catch behind both shoulders is legal if rope goes up heels.
19. One hind foot receives a 5-second penalty.
20. The steer's entire body must be turned and moving forward in tow before the heel loop can be thrown. However, if the steer stops it must only be in tow for the heel loop to be legal. Any heel loop thrown in the switch is considered a crossfire and is illegal and will receive a no time.
21. Steer must not be handled roughly at any time, and ropers may be disqualified if, in the opinion of the field judge that they have intentionally done so. Ropers may not be abusive to their mounts either.
22. In the event a team roper is disqualified or injured, that team will be eliminated from that event.
23. If header accidentally jerks steer off his feet or steer trips or falls, header must not drag steer over eight feet before steer regains his feet or team will receive no score.
24. Broken rope or dropped rope will be considered a no time.
25. Time will be taken when steer is roped, both horses facing steer in line with ropes dallied and tight, horse's front feet must be on the ground.

#### SECTION 14: MINI MITE FIGURE 8

1. Contestant may start on either side.
2. 60 second time limit.
3. Figure 8 pattern will run around 2 poles.
4. Penalty for knocking over a pole is five (5) seconds.
5. Breaking the pattern will result in a no time.

#### FIGURE 8 PATTERN

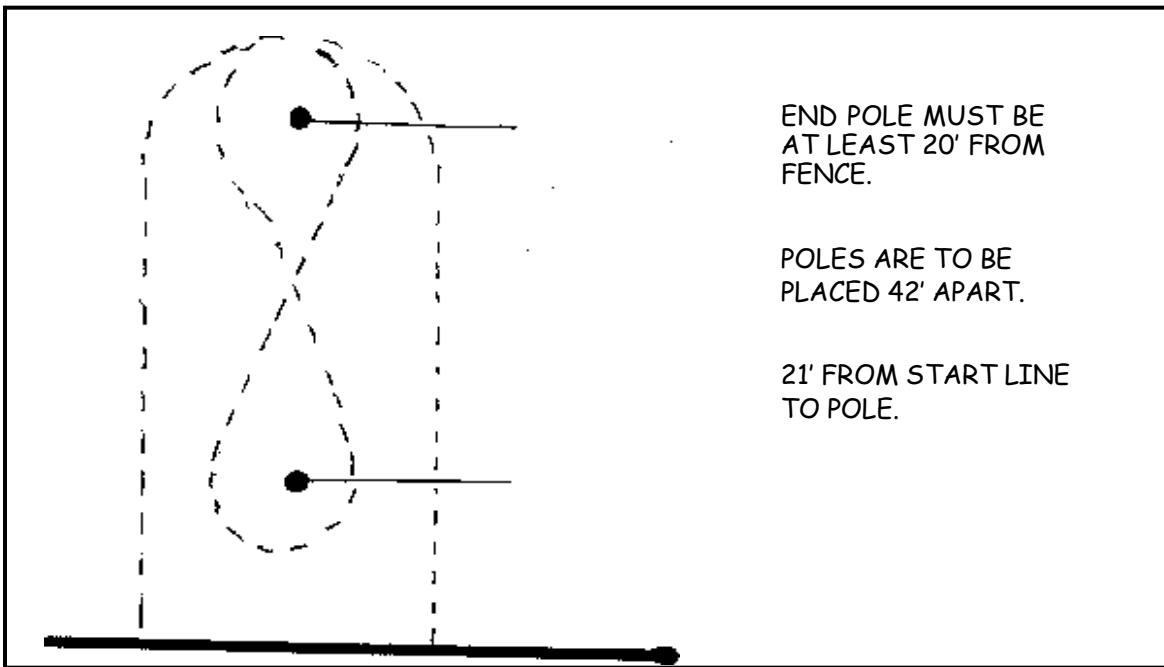

#### SECTION 15: PEE WEE CALF RIDING / JUNIOR STEER RIDING / COW RIDING

1. Each contestant shall furnish their own equipment including a rope and bell (bell is required). Mouth guards, protective vests, and helmets are optional in the calf riding and steer riding, but they are required in the Cow Riding. Ropes with knots, wires, or other devices used for the purpose of placing spurs therein will be considered "illegal equipment". Only dry resin may be used on calf riding equipment.
2. A loose rope, with or without a handhold will be used. No knots, hitches or double wrap-around hand to prevent rope from falling off when the rider leaves the animal are permitted.
3. Riding will be done one hand or both hands, however, must be consistent throughout the entire ride or the contestant will be disqualified. Cow Riding must use one hand only.
4. PEE WEE CALF RIDING: 8 second time for a qualified ride.  
 JUNIOR STEER RIDING: 8 second time for a qualified ride.  
 SENIOR COW RIDING: 8 second time for a qualified ride.
5. Time begins when animal crosses the plane of the chute.
6. Rider and animal to be marked equally.
7. Flanking the animal is at the option of the rider in the calf riding and the steer riding, cows must be flanked in the Cow Riding.
8. Stock will be loaded into the chutes, and the contestant first in the draw will compete on the stock loaded in the first chutes and so on in a like manner.
9. Contestants will be disqualified for losing the rope, being bucked off, illegal hand hold, sharpened or locked rowels, touching anything, including the animal, equipment or person with free hand, placing spurs or chaps under the rope when the rope is being tightened, changing hands on the rope, wrapping the rope around hand, using unapproved substance on equipment or not being ready when called.

10. Stock contractors will have the right to have judges pass on whether equipment is objectionable. Judges are to inspect all equipment.
11. Contestants will have the right to call judges to pass on whether or not animal is properly flanked and cinched and equipment is properly set. Judges have the authority to disallow dangerous wraps.
12. If an animal falls or if rider is knocked off at the chute, a re-ride may be granted at the judge's discretion.
13. Event will be offered only at rodeos held in an arena with bucking chutes. The event will not be offered in advance or on a slack basis in place of rodeos where no bucking chute is available.

## Score Line Diagrams

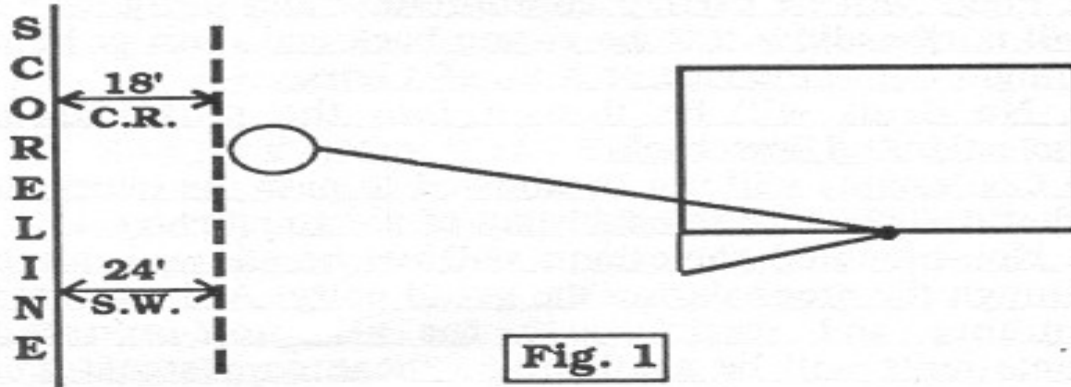

**SCORE LENGTHS:** Length of the score line to be determined according to the livestock, the length of the arena, and the arena conditions. All score lengths are subject to Directors' or representatives' approval.

**CR,BK:** Minimum length of score will be the length of the roping box minus four (4) feet. Maximum length of score will be eighteen (18) feet.

**SW:** The score may be no longer than the length of the steer wrestling box minus six (6) feet, unless the box is less than fourteen (14) feet. In that instance the length of the score would be a maximum of the length of the box minus five (5) feet.

**TR:** The minimum length of the team roping score line shall be the length of the box minus two (2) feet.

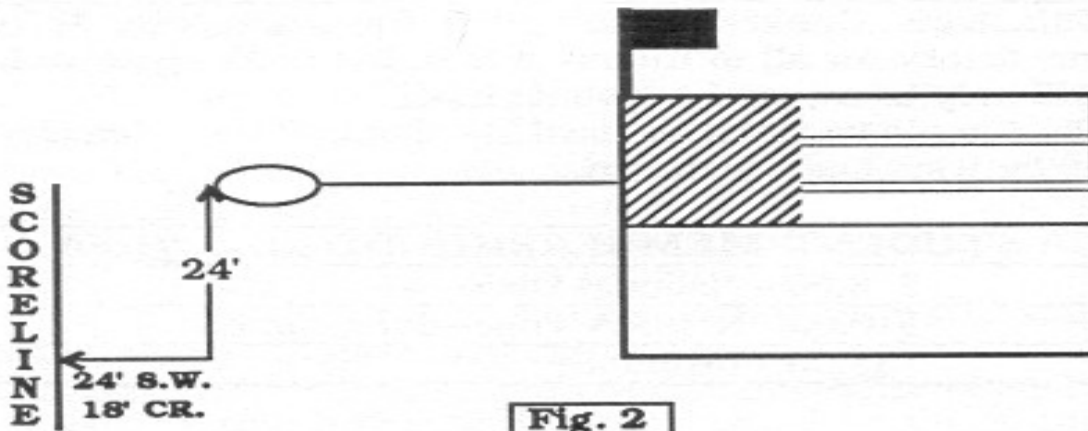

# BARREL RACING PATTERN

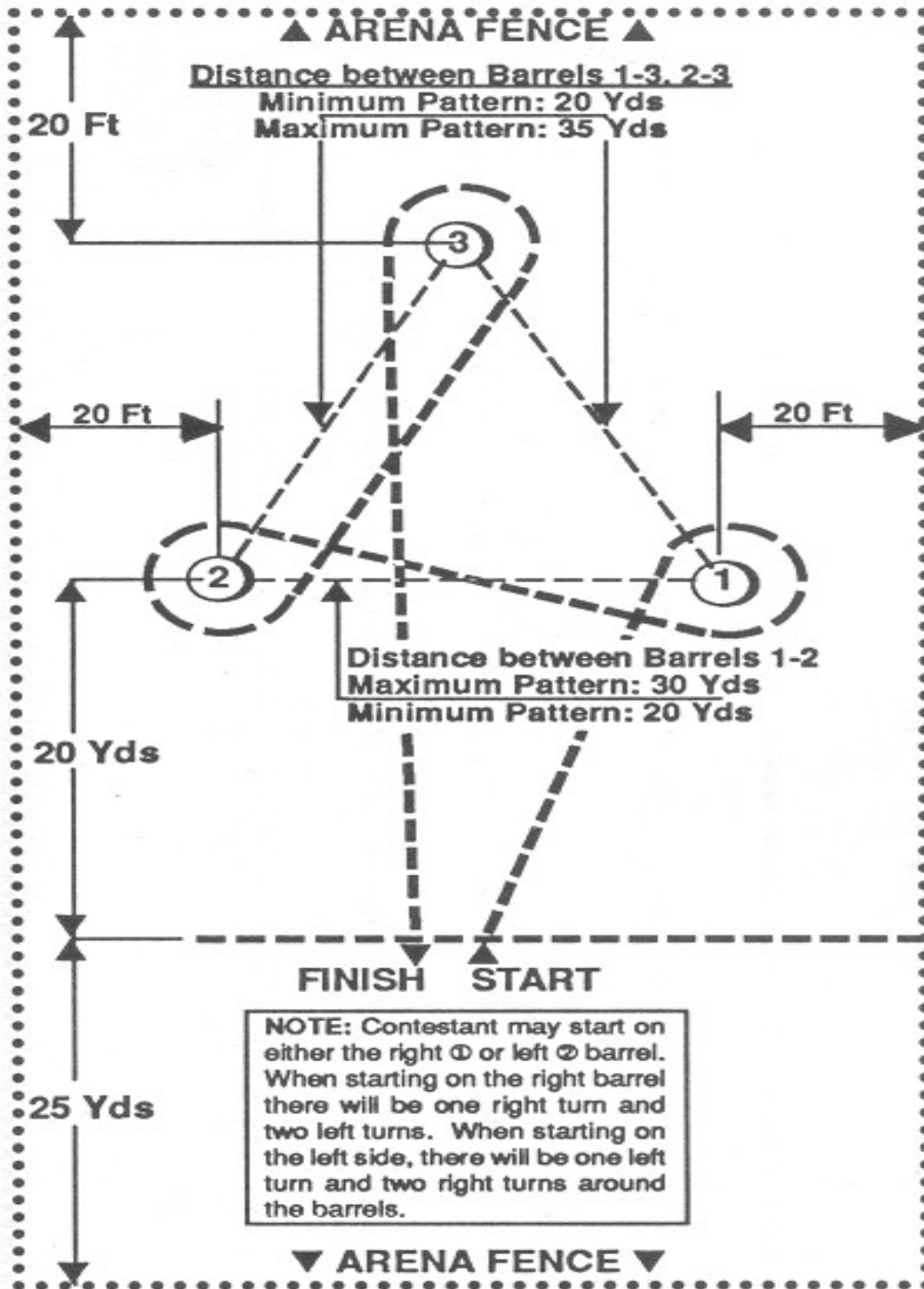

# POLE BENDING PATTERN

